



Standard Test Method for Rubber Property—Durometer Hardness¹

This standard is issued under the fixed designation D2240; the number immediately following the designation indicates the year of original adoption or, in the case of revision, the year of last revision. A number in parentheses indicates the year of last reapproval. A superscript epsilon (ϵ) indicates an editorial change since the last revision or reapproval.

This standard has been approved for use by agencies of the U.S. Department of Defense.

1. Scope

1.1 This test method covers twelve types of rubber hardness measurement devices known as durometers: Types A, B, C, D, DO, E, M, O, OO, OOO, OOO-S, and R. The procedure for determining indentation hardness of substances classified as thermoplastic elastomers, vulcanized (thermoset) rubber, elastomeric materials, cellular materials, gel-like materials, and some plastics is also described.

1.2 This test method is not equivalent to other indentation hardness methods and instrument types, specifically those described in Test Method [D1415](#).

1.3 This test method is not applicable to the testing of coated fabrics.

1.4 All materials, instruments, or equipment used for the determination of mass, force, or dimension shall have traceability to the National Institute for Standards and Technology, or other internationally recognized organizations parallel in nature.

1.5 The values stated in SI units are to be regarded as standard. The values given in parentheses are for information only. Many of the stated dimensions in SI are direct conversions from the U. S. Customary System to accommodate the instrumentation, practices, and procedures that existed prior to the Metric Conversion Act of 1975.

1.6 *This standard does not purport to address all of the safety concerns, if any, associated with its use. It is the responsibility of the user of this standard to establish appropriate safety and health practices and determine the applicability of regulatory limitations prior to use.*

2. Referenced Documents

2.1 ASTM Standards:²

¹ This test method is under the jurisdiction of ASTM Committee [D11](#) on Rubber and is the direct responsibility of Subcommittee [D11.10](#) on Physical Testing.

Current edition approved Aug. 1, 2015. Published January 2016. Originally approved in 1964. Last previous edition approved in 2010 as D2240 – 05 (2010). DOI: 10.1520/D2240-15.

² For referenced ASTM standards, visit the ASTM website, www.astm.org, or contact ASTM Customer Service at service@astm.org. For *Annual Book of ASTM Standards* volume information, refer to the standard's Document Summary page on the ASTM website.

[D374 Test Methods for Thickness of Solid Electrical Insulation \(Withdrawn 2013\)](#)³

[D618 Practice for Conditioning Plastics for Testing](#)

[D785 Test Method for Rockwell Hardness of Plastics and Electrical Insulating Materials](#)

[D1349 Practice for Rubber—Standard Conditions for Testing](#)

[D1415 Test Method for Rubber Property—International Hardness](#)

[D4483 Practice for Evaluating Precision for Test Method Standards in the Rubber and Carbon Black Manufacturing Industries](#)

[F1957 Test Method for Composite Foam Hardness—Durometer Hardness](#)

2.2 ISO Standard:⁴

[ISO/IEC 17025: 1999 General Requirements for the Competence of Testing and Calibration Laboratories](#)

3. Summary of Test Method

3.1 This test method permits hardness measurements based on either initial indentation or indentation after a specified period of time, or both. Durometers with maximum reading indicators used to determine maximum hardness values of a material may yield lower hardness when the maximum indicator is used.

3.2 The procedures for Type M, or micro hardness durometers, accommodate specimens that are, by their dimensions or configuration, ordinarily unable to have their durometer hardness determined by the other durometer types described. Type M durometers are intended for the testing of specimens having a thickness or cross-sectional diameter of 1.25 mm (0.050 in.) or greater, although specimens of lesser dimensions may be successfully accommodated under the conditions specified in Section 6, and have a Type M durometer hardness range between 20 and 90. Those specimens which have a durometer hardness range other than specified shall use another suitable procedure for determining durometer hardness.

³ The last approved version of this historical standard is referenced on www.astm.org.

⁴ Available from International Organization for Standardization (ISO), 1 rue de Varembe, Case postale 56, CH-1211, Geneva 20, Switzerland.

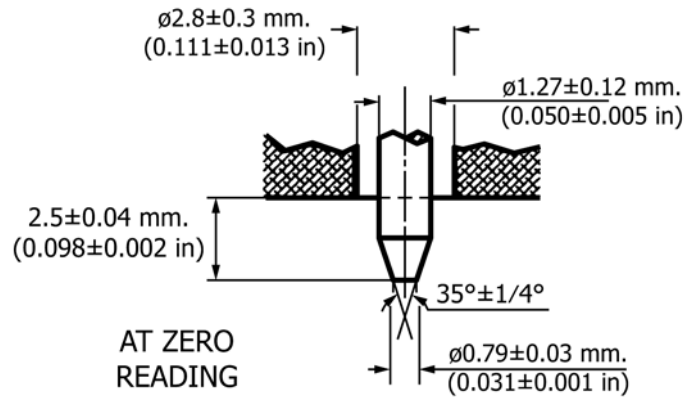

FIG. 1 (a) Type A and C Indentor

4. Significance and Use

4.1 This test method is based on the penetration of a specific type of indenter when forced into the material under specified conditions. The indentation hardness is inversely related to the penetration and is dependent on the elastic modulus and viscoelastic behavior of the material. *The geometry of the indenter and the applied force influence the measurements such that no simple relationship exists between the measurements obtained with one type of durometer and those obtained with another type of durometer or other instruments used for measuring hardness.* This test method is an empirical test intended primarily for control purposes. No simple relationship exists between indentation hardness determined by this test method and any fundamental property of the material tested. For specification purposes, it is recommended that Test Method D785 be used for materials other than those described in 1.1.

5. Apparatus

5.1 *Hardness Measuring Apparatus, or Durometer, and an Operating Stand, Type 1, Type 2, or Type 3* (see 5.1.2) consisting of the following components:

5.1.1 Durometer:

5.1.1.1 *Presser Foot*, the configuration and the total area of a durometer presser foot may produce varying results when there are significant differences between them. It is recommended that when comparing durometer hardness determinations of the same type (see 4.1), that the comparisons be between durometers of similar presser foot configurations and total area, and that the presser foot configuration and size be noted in the Hardness Measurement Report (see 10.2.4 and 5.1.1.3).

5.1.1.2 *Presser Foot, Types A, B, C, D, DO, E, O, OO, OOO, and OOO-S*, with an orifice (to allow for the protrusion of the indenter) having a diameter as specified in Fig. 1 (a, b, c, d, e, f, and g), with the center a minimum of 6.0 mm (0.24 in.) from any edge of the foot. When the presser foot is not of a flat circular design, the area shall not be less than 500 mm² (19.7 in.²).

NOTE 1—The Type OOO and the Type OOO-S, designated herein,

differ in their indenter configuration, spring force, and the results obtained. See Table 1 and Fig. 1 (e and g).

5.1.1.3 *Presser Foot*—flat circular designs designated as Type *xR*, where *x* is the standard durometer designation and *R* indicates the flat circular presser foot described herein, for example, Type *aR*, *dR*, and the like. The presser foot, having a centrally located orifice (to allow for the protrusion of the indenter) of a diameter as specified in Fig. 1 (a through g). The flat circular presser foot shall be 18 ± 0.5 mm (0.71 ± 0.02 in.) in diameter. These durometer types shall be used in an operating stand (see 5.1.2).

(a) Durometers having a presser foot configuration other than that indicated in 5.1.1.3 shall not use the Type *xR* designation, and it is recommended that their presser foot configuration and size be stated in the Hardness Measurement Report (see 10.2.4).

5.1.1.4 *Presser Foot, Type M*, with a centrally located orifice (to allow for the protrusion of the indenter), having a diameter as specified in Fig. 1 (d), with the center a minimum of 1.60 mm (0.063 in.) from any edge of the flat circular presser foot. The Type M durometer shall be used in a Type 3 operating stand (see 5.1.2.4).

5.1.1.5 *Indenter*, formed from steel rod and hardened to 500 HV10 and shaped in accordance with Fig. 1 (a, b, c, d, e, or g), polished over the contact area so that no flaws are visible under 20× magnification, with an indenter extension of 2.50 ± 0.04 mm (0.098 ± 0.002 in.).

5.1.1.6 *Indenter, Type OOO-S*, formed from steel rod and hardened to 500 HV10, shaped in accordance with Fig. 1 (f), polished over the contact area so that no flaws are visible under 20× magnification, with an indenter extension of 5.00 ± 0.04 mm (0.198 ± 0.002 in.).

5.1.1.7 *Indenter, Type M*, formed from steel rod and hardened to 500 HV10 and shaped in accordance with Fig. 1 (d), polished over the contact area so that no flaws are visible under 50× magnification, with an indenter extension of 1.25 ± 0.02 mm (0.049 ± 0.001 in.).

5.1.1.8 *Indenter Extension Indicator*, analog or digital electronic, having a display that is an inverse function of the indenter extension so that:

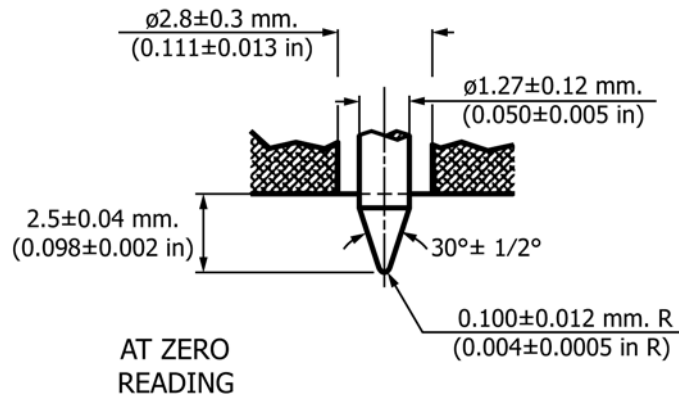

FIG. 1 (b) Type B and D Indentor (continued)

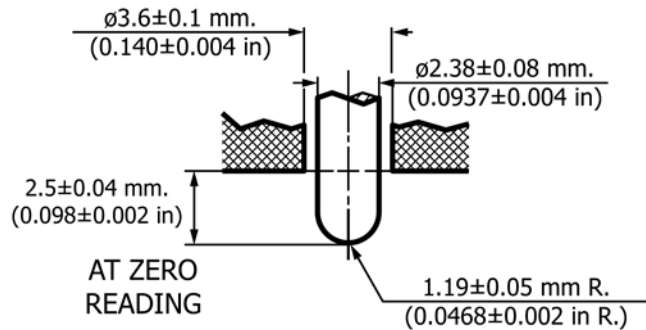

FIG. 1 (c) Type O, DO, and OO Indentor (continued)

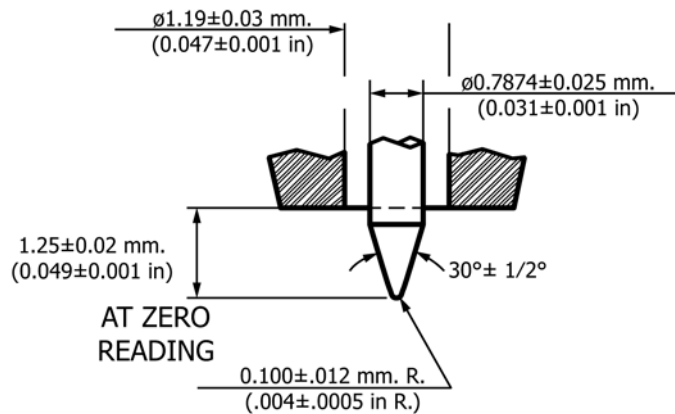

FIG. 1 (d) Type M Indentor (continued)

(1) The display shall indicate from 0 to 100 with no less than 100 equal divisions throughout the range at a rate of one hardness point for each 0.025 mm (0.001 in.) of indenter movement,

(2) The display for Type OOO-S durometers shall indicate from 0 to 100 with no less than 100 equal divisions throughout the range at a rate of one hardness point for each 0.050 mm (0.002 in.) of indenter movement,

(3) The display for Type M durometers shall indicate from 0 to 100 with no less than 100 equal divisions at a rate of one hardness point for each 0.0125 mm (0.0005 in.) of indenter movement, and

(4) In the case of analog dial indicators having a display of 360°, the points indicating 0 and 100 may be at the same point on the dial and indicate 0, 100, or both.

5.1.1.9 *Timing Device (optional)*, capable of being set to a desired elapsed time, signaling the operator or holding the hardness reading when the desired elapsed time has been reached. The timer shall be automatically activated when the presser foot is in contact with the specimen being tested, for example, the initial indenter travel has ceased. Digital electronic durometers may be equipped with electronic timing